



Nouvelle Kemuning Industrial Park

BUKIT RIMAU



The Hub Of The Future

CORPORATE FACTORY

A Great Value Chic Looking Modern Industrial Premise



FREEHOLD

Artist's Impression



Artist's Impression

A Design That Reflects Authenticity, Excellence And Vision

The concept and the choice of location as well as the architecture bear testament to these three elements. This factory represents perfectly what a modern sophistication is.

Furnished with the finest finishing, each factory in **Nouvelle Kemuning Industrial Park** comes with generous, practical yet functional built-up to satisfy every industrial need – administration, production and to showcase your products, where all can function under one roof.

3-Storey Semi-Detached Factory: Corporate Factory | Executive Office | Factory Showroom

- Situated right amidst the region's action, which allows employers to tap into a huge pool of experienced and skilled workers
- Designed for optimal ventilation, lighting and visibility
- Futuristic design with green features that make the factory energy and water efficient
- Practical interior, maximum space, quality finishes with doorstep convenience
- Built-up area: 7,140 sf - 14,600 sf
- Land size: 10,039 sf - 19,906 sf





Floor Plan

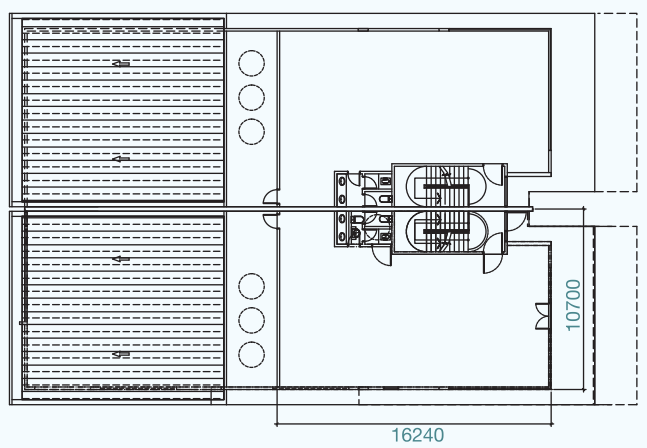

Second Floor Plan - Type A2

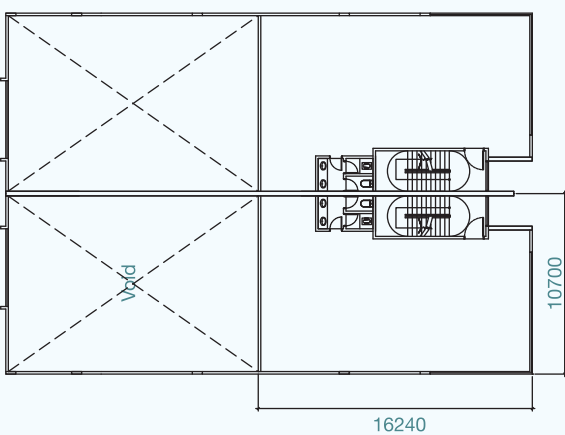

First Floor Plan - Type A2

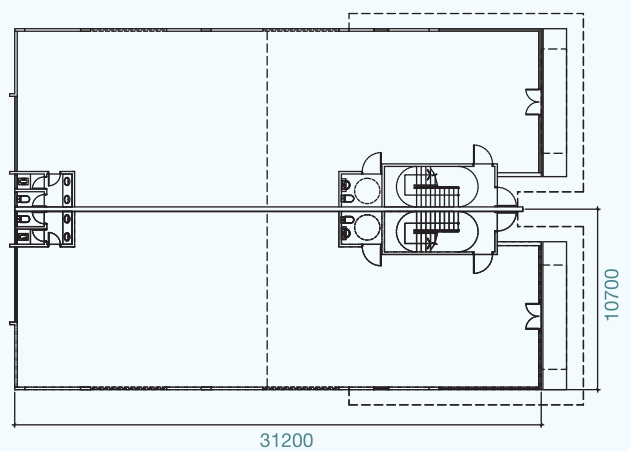

Ground Floor Plan - Type A2

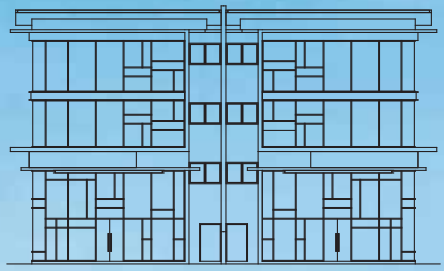

Nouvelle Kemuning Industrial Park

BUKIT RIMAU



Specifications

Structure

Reinforced concrete

Roofing

Metal deck roofing c/w roof insulation

Ceiling

Asbestos-free flat ceiling / skim coat

Wall

Brick wall with cement plastering

Wall Finishes

- Toilet - homogeneous tiles (full height)
- Others - generally plastered & painted

Floor Finishes

Ground Floor

- Toilet - homogeneous tiles
- Others - cement render

First Floor

- Toilet - homogeneous tiles
- Others - cement render

Second Floor

- Toilet - homogeneous tiles
- Others - cement render

Painting

- Exterior Walls - weather resistant paint
- Interior Walls - emulsion paint

Windows

- Aluminium frame window
- Aluminum frame fixed louvers

Door

- M.S. frame plywood flush door
- Motorised roller shutter
- Auto gate

Staircase

Homogeneous tiles

Sanitary Fittings

Ground floor

- Wash basin - 2 Nos.
- W.C. - 1 No.
- Squatting - 1 No.

First Floor

- Wash basin - 2 Nos.
- W.C. - 2 Nos.

2nd Floor

- Wash basin - 2 Nos.
- W.C. - 2 Nos.

Electrical Fittings

- Lighting point - 50 Nos.
- Power point - 30 Nos.
- Phone point - 5 Nos.



Note: All the above items are subject to variations, modifications and substitutions as required by the Authorities or recommended by the Architect or Engineer.

Site Plan

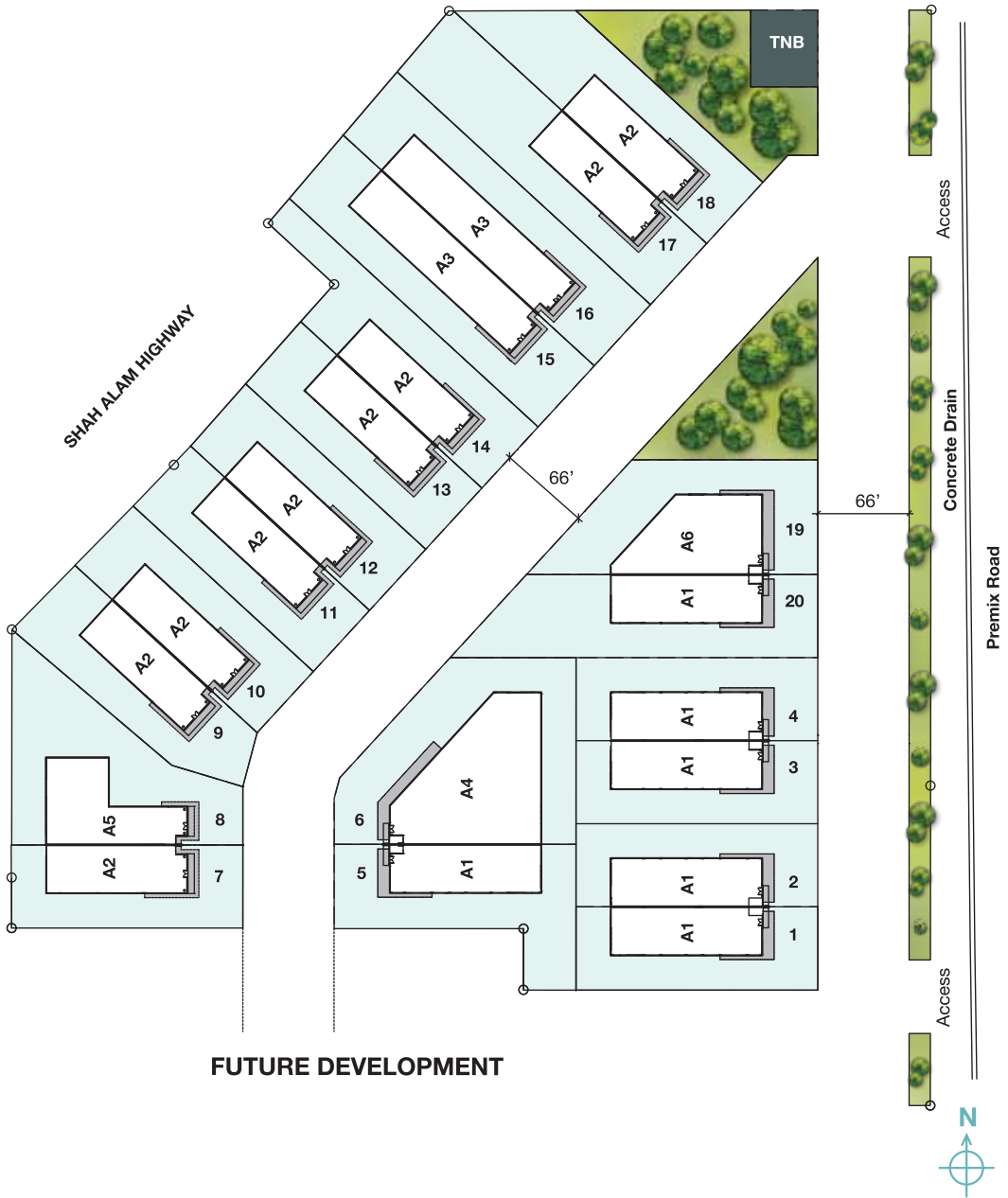

Security Concept

Safeguard your property and your employees' wellbeing

- Limited units to prevent unnecessary congestion
- Open layout for practical flexibility
- Guarded for better security and assurance



Strategic Location

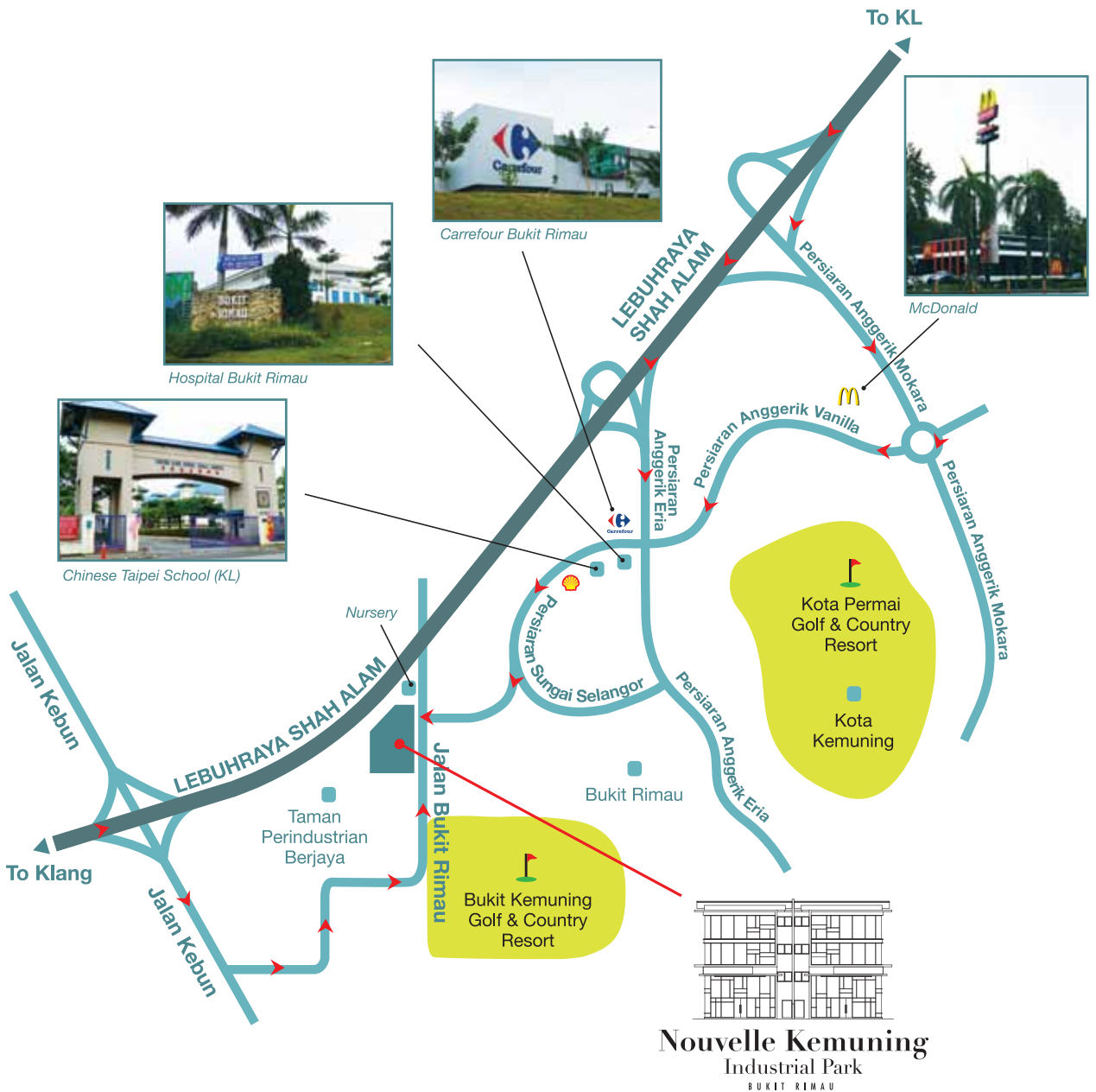

Modern Sophisticated Meets Doorstep Convenience

Nouvelle Kemuning Industrial Park is located at the doorstep of the fastest growing part of Shah Alam and next to the vibrant lifestyle community, Bukit Rimau, offering a choice address for ambitious entrepreneurs. It is a trendy industrial development that blends excellent connectivity and amenities with elegant architecture.

Ease of travel to major destinations in the Klang Valley via major highway networks.



A Joint Development By:



Developer:

GAINVEST HOLDINGS SDN. BHD. (161765-V)

No.69, Jalan SS6/10, Kelana Jaya, 47301 Petaling Jaya, Selangor Darul Ehsan, Malaysia.

Hotline : 016-307 8888